

Fiber Bragg gratings, originally developed to multiplex signals in optical networks, are now allowing sensors to detect strain, pressure, temperature changes, and other physical properties.

Arturo Chavez-Pirson,
NP Photonics

The Basics of Fiber Bragg Gratings

Fiber-optic sensors evolved from technology originally developed for telecommunications, and the wave of investment in that sector during the nineties both improved the performance of fiber sensing components and helped reduce their relative cost. This trend served to enhance the intrinsic advantages that photonic sensors have always presented when compared to their conventional electronic and electromechanical counterparts.

Fiber-optic sensors tend to be smaller and lighter weight than electronic devices, and they deliver superior speed, sensitivity, and bandwidth. The dielectric glass or plastic materials constituting optical fiber make these sensors passive and immune to EMI. This ensures reliable operation even when placed close to large electrical equipment such as generators or motors, and reduces potential damage to the sensing element (or remote electronics) if lightning strikes nearby. Because fiber-optic sensors generate neither heat nor sparks, they can safely be used in hazardous environments such as oil refineries, grain bins, mines, and chemical processing plants. Nor will standard glass fibers lose any of their performance in corrosive environments or at temperatures reaching 450°F. Special fibers can extend sensor operation above 1200°F.

Because its sensing and signal propagation functions rely on photons rather than electrons, a single segmented fiber can form distributed or arrayed sensors covering large areas. The same strand can also convey the sensed information to a remote interrogation unit up to kilometers away. With further modifications, fiber elements can form many signal processing devices (e.g., splitters, combiners, multiplexers, filters, delay lines), making all-fiber measuring systems possible.

These advantages and fiber's geometric versatility have found innumerable applications with tight space requirements, harsh environments, or EMI and RFI. More specifically, fiber sensors are increasingly used to measure strain, temperature, pressure, angular rotation speed, acceleration, and many other parameters. Currently, they can be found measuring strain in bridges, wind generator blades, oil tankers, and high-rise buildings and other structures, as well as monitoring temperature and pressure at the bottom of oil wells and reservoirs. Fiber-optic sensing systems have also found work in security and counter-terrorism applications. ►



Strain and pressure sensors, for example, can potentially help detect intruders or changes in environmental conditions over a wide geographical area

Fiber Sensor Components

The most common sensing element for fiber-optic sensors is based on fiber Bragg gratings (FBGs), a technology originally developed to multiplex signals in optical networks. Consisting of a periodic variation etched directly into the core of an optical fiber (see Figure 1), FBGs create a partially reflective mirror that returns selective wavelengths in the form of a narrow spectral peak determined by the grating’s period. A single strand of fiber can have multiple gratings etched along its length, forming an array of sensors to be probed by a multiple-channel interrogation system. A change in the periodicity of any grating along the array will alter the spectral peak on the corresponding channel and signify a change in temperature, longitudinal strain, or other physical influences on the fiber at the grating’s location.

Besides the fiber component, a FBG sensor typically consists of a light source to illuminate the grating or array, and a detector system to monitor the reflected wavelengths. Either the source or the detector element must be tunable in order to continuously

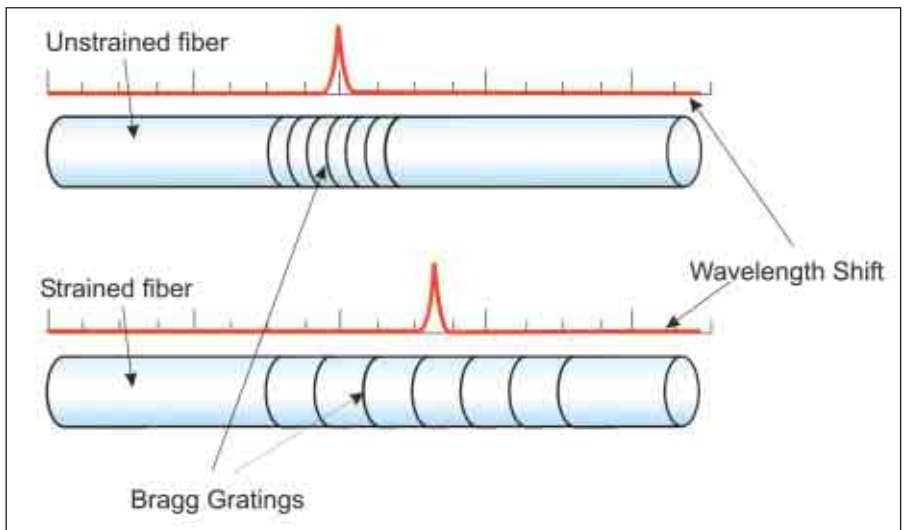

Figure 1. Fiber Bragg gratings are etched directly into the core of an optical fiber and, like a prism, disperse different colors (wavelengths) at different angles. Because these wavelengths are confined within a single-mode fiber, however, only a select few are able to propagate. The number and frequency of candidate wavelengths depends on the periodicity of the grating, which is sensitive to changes in temperature and fiber tension. Environmental changes at the grating location can therefore be detected as a change in wavelength.

scan the wavelength range of the FBG and detect any shifts relative to the source’s wavelength. In either case, system sensitivity depends on the wavelength accuracy of either the source or the detector.

Some systems use a narrowband or tunable laser source and a broadband detector. However, broadband sources such as LEDs, superluminescent LEDs (SLEDs), or ampli-

fied-spontaneous emission (ASE) white light sources are less costly and generally suitable for illuminating small sensor arrays. The simplest, most cost-effective systems combine ASEs with a tunable filter at the detector.

These sources are essentially an optical amplifier without an input signal, and their output spans the peak transmission window of optical fiber, between 1520 and 1620 nm. This enables them to simultaneously interrogate multiple sensors in parallel. Furthermore, because ASE sources are entirely fiber based, their light generation occurs within the fiber core; this translates into much higher output power and a smoother ripple-free spectrum compared to SLEDs.

Their most significant and practical benefit, however, is that ASEs can deliver higher output powers, reaching 16 dBm and above, so they can accommodate denser arrays. This is particularly beneficial for applications requiring more than 12 sensors along a single fiber strand—monitoring strain over large distances, for example, or measuring multiple parameters at a single location.

Sensor Limits

Although FBG arrays may extend along wide physical geometries, they typically operate within a limited wavelength range, from 1520 to 1620 nm. This requires larger arrays to cram more spectral peaks within a limited optical region. Dense arrays may

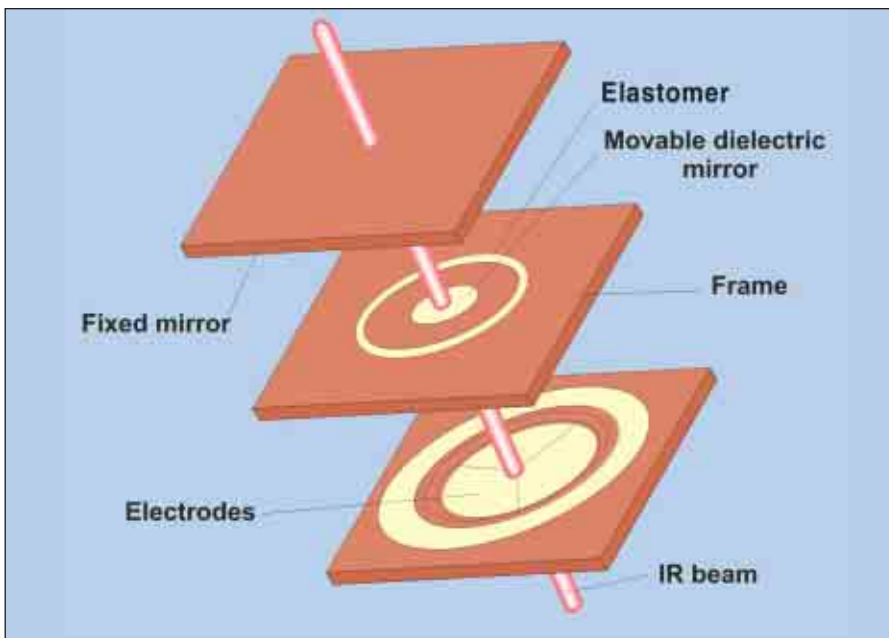

Figure 2. Many fiber-optic sensors probe specific wavelengths using a pair of microscopic mirrors—one fixed, the other movable—that vary their separation and establish a tunable spectral peak. One particular design incorporates elastomeric materials to support the mirrors, rendering a more stable and rugged configuration.

space peaks by as little as 5 nm apart, which translates into no more than 20 sensors in a single strand of fiber, regardless of how long the fiber extends.

This relatively large spacing stems from the limited power of conventional light sources, which must divide their finite output among all the gratings in an array. The more gratings that require illumination, the less light each one may reflect. In addition, more closely spaced channels require higher resolution at the detector end to distinguish the separate peaks.

Solutions to this problem are emerging. New high-power ASE sources combined with extremely high-performance optical spectrum analyzers (OSAs) allow sensor gratings to be grouped within tighter spectral windows. In practical terms, this allows sensor systems to monitor multiple elements with high accuracy. It also enables source and detector components to be integrated on a single PCI card, in a box, or as an OEM module to enable a robust, handheld unit.

The operating principles for fiber sensors are similar to those that apply to instruments used for monitoring optical networks. Many of these instruments track signals by means of scanning Fabry-Perot interferometers, which require only a single-element photodetector to measure multiple channels. Different Fabry-Perot filters have different tuning methods. One versatile approach uses MEMS consisting of multiple tiny mirror pairs; in each pair one is fixed, the other movable. The separation between these mirrors establishes a single peak within a given wavelength band. So applying electrostatic forces to the movable mirror alters the spacing, tuning the filter across its free spectral range. A change in mirror separation of 1 micron, for example, can tune a single resonance peak across 100 nm.

An alternative MEMS approach (see Figure 2, page 19) incorporates *compliant* elastomeric materials to support the movable mirror, hence the name C-MEMS. These materials are as much as six orders of magni-

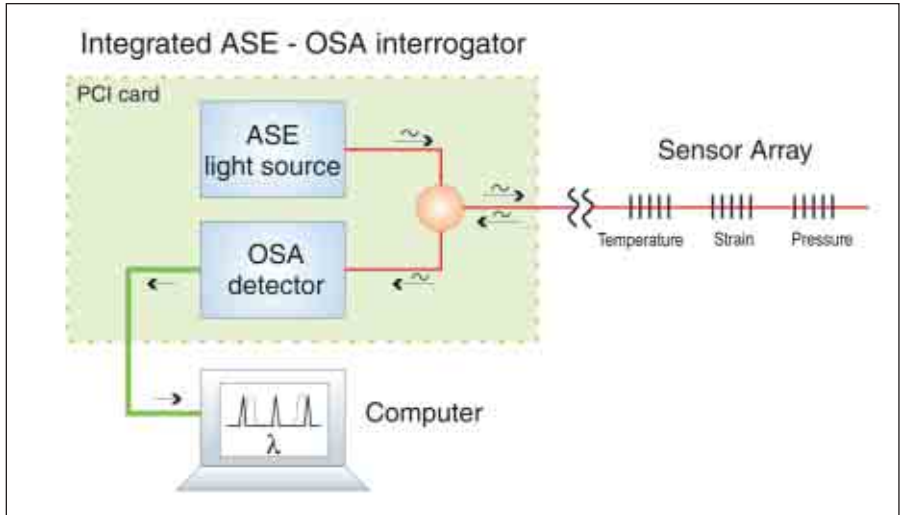
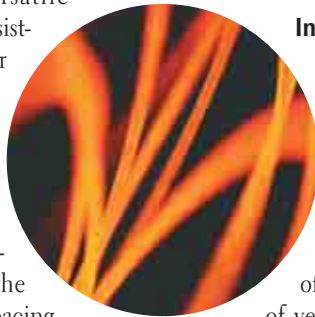

Figure 3. A simple, cost-effective fiber sensor configuration combines amplified-spontaneous emission (ASE) white light sources with optical spectrum analyzers (OSAs), all mounted on a single PCI card. Photons emitted by the fiber-based ASE source travel to the sensor gratings and return via fiber to the OSA detector. There, they are converted to electronic signals that a computer can analyze. Shifts in the optical signal indicate a perturbation at the sensing array.

tude less stiff than silicon and have excellent mechanical, chemical, and thermal stability. Compared with traditional silicon-based MEMS, elastomer-based C-MEMS are far more rugged, lasting more than 20 years. Electrostatic force is enough to drive the mirrors and keep them parallel over the lifetime of the device, regardless of ambient vibrations, shocks, or fluctuating temperatures.

Integrated Answers

C-MEM tunable filters are the basis of OSA systems' ability to scan multiple gratings for changes in wavelength or power. OSAs based on this technology deliver detection resolutions of 1 pm, allowing the handling of very dense sensor arrays illuminated by high-power, stable ASE sources.

Integrated configurations reduce costs and space requirements by sharing packaging and electronics. They also minimize system design complexity. One potential disadvantage of conventional ASEs is the tilt or spectral shape (i.e., the output power varies as a function of wavelength). The common solution is to add a gain-flattening filter to flat-

ten the spectral shape. These filters add both cost and complexity to sensor systems.

Integrating the source and detector (see Figure 3) enables engineers to calibrate them, shaping the ASE source spectrum to the ideal form required for optimum analysis. The OSA can effectively do a normalization computation to subtract out the ASE spectral dependency. This saves costs by eliminating the gain-flattening filter and ensuring accurate, relative power changes attributable to the sensor elements instead of the source.

In short, calibrated ASE sources provide extraordinarily stable, high-power illumination sources, while OSAs based on C-MEMs tunable filters provide accurate resolution down to 1 pm. In this way, integrated ASE/OSA systems represent the vanguard of what fiber sensor technology has to offer: a complete, yet simple, reliable, cost-effective tool to interrogate dense FBG sensor arrays. ■

Dr. Arturo Chavez-Pirson is Director of Technology Development, NP Photonics, Tucson, AZ; 520-799-7438, chavez@np Photonics.com, www.npphotonics.com.

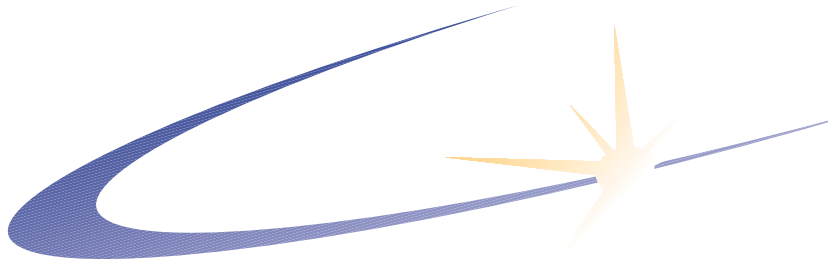

NP Photonics

Philippe Brak
VP Sales & Marketing
Tel: (Direct) 520-799-7496
(Main) 520-799-7400
Email: pbrak@np Photonics.com